

B.TECH. DEGREE EXAMINATION, AUGUST 2021

I B.Tech. I Semester**BASIC ELECTRICAL SCIENCES**
(Electrical & Electronics Engineering)

Time : 3Hrs

Max. Marks : 60

Answer *SIX* Questions, Choosing *ONE* Question from each section
All Questions carry equal marks

* * *

SECTION - I

1. (a) Write the voltage-current relationships for the three passive elements and derive the expressions for power in each case.
(b) Calculate the voltage V_x in the circuit shown below.

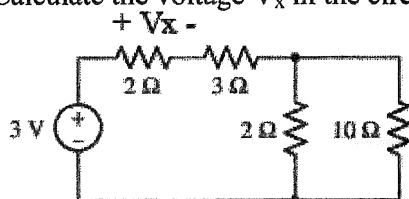

2. (a) Derive the conversion equations for star to delta transformation for a resistive network.
(b) Determine the equivalent resistance between the terminals A and B in the figure shown below.

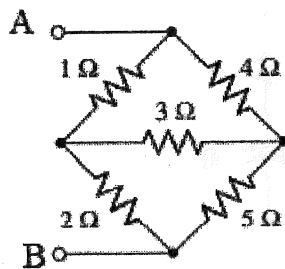
**SECTION - II**

3. (a) The voltage across a 5Ω resistor is $v(t) = 100 \sin 20t$. What is the sinusoidal expression for the current? Sketch the v and i curves.
(b) Find the RMS value of the voltage waveform over one full cycle in the figure shown below.

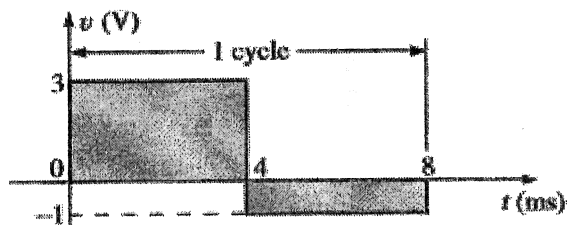

4. (a) Determine the phasor quantities for the circuit shown below: (i) V_R , (ii) V_C , and (iii) power factor.

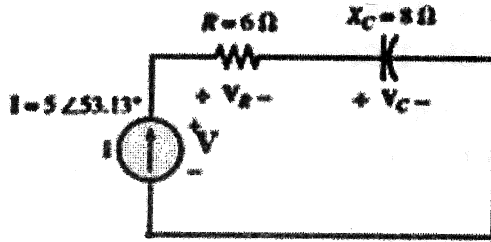

- (b) Find the active, reactive and apparent powers being delivered to an impedance, $Z_L = (8 - j11) \Omega$ by a current $I = 5 \angle 20^\circ$ A.

SECTION - III

5. (a) Using the current divider rule, find the current through each impedance in Figure shown below, and represent them in a phasor diagram.

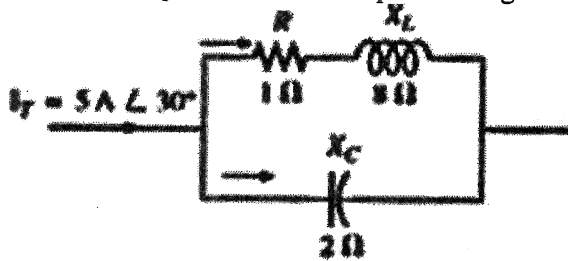

- (b) For the network shown in Fig. below, find (i) P_T , (ii) Q_T , (iii) S_T , and (iv) power factor for the system. Sketch the power triangle.

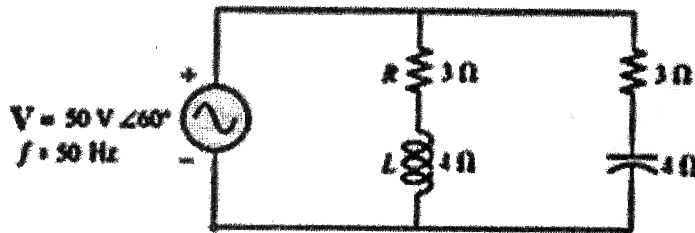

6. (a) Define the terms: (i) graph (ii) twig (iii) link (iv) tree.
 (b) Construct a graph for the circuit shown below and draw a (i) tree (with twigs: 1,3,4,6) and (ii) co-tree. Here A, B, C, D, E are nodes and 1,2,3,4,5,6,7 are elements of the given circuit.

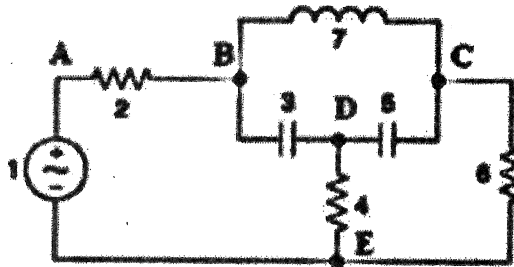

SECTION - V

9. (a) For the circuit shown below, draw the dotted equivalent circuit and find the equivalent inductance.

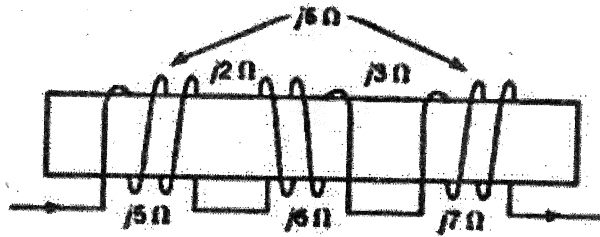

- (b) Define the following terms with respect to a coupled coil:
 (i) self-inductance, (ii) mutual inductance and (iii) coefficient of coupling.
10. (a) Write the mesh equations for the circuit shown in figure below.

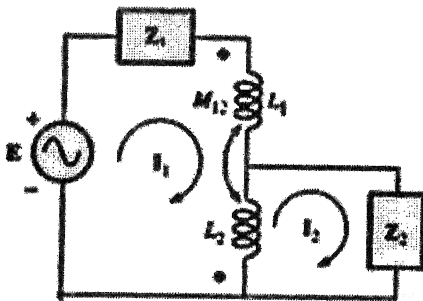

- (b) In a pair of coils, with $L_1 = 0.1$ H and $L_2 = 0.2$ H, at a certain moment, $i_1 = 4$ A and $i_2 = 10$ A. Find the total energy in the coils if the coupling coefficient M is 0.1 H.

SECTION - VI

11. (a) Derive the expression for resonant frequency in a series R-L-C circuit.
 (b) Compute the resonant frequency, and quality factor of an RLC series circuit, with $R = 20 \Omega$, $L = 50$ mH, and $C = 1 \mu\text{F}$.
12. (a) Prove that the current locus diagram for a series R-C circuit with fixed reactance and variable resistance is a circle.
 (b) Draw the impedance and admittance locus diagrams for a series R-L circuit with fixed resistance and variable reactance. Show the necessary expressions used.

SECTION - IV

7. (a) Apply mesh analysis to the network shown in Figure below and compute the currents flowing through the resistors R_1 and R_3 .

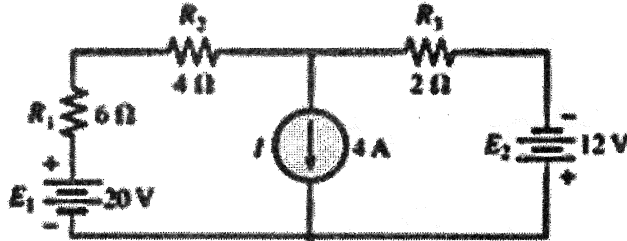

- (b) Determine the current in the branch AB of the network below using nodal analysis.

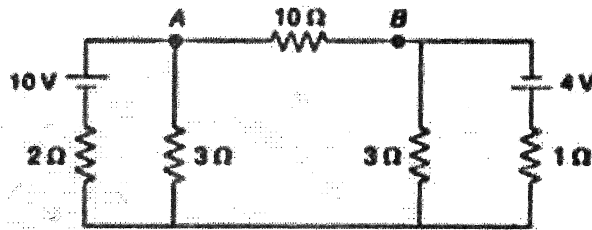

8. (a) Use mesh analysis on the circuit of Figure shown below to find I_1 and I_2 .

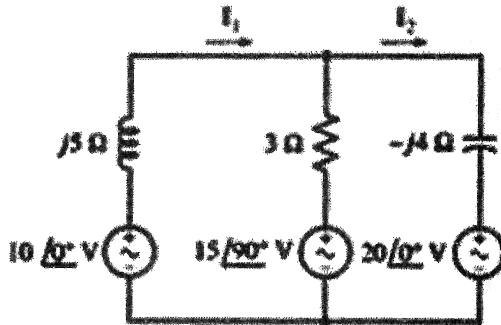

- (b) Calculate the current through the capacitor in the network of Figure below using nodal analysis.

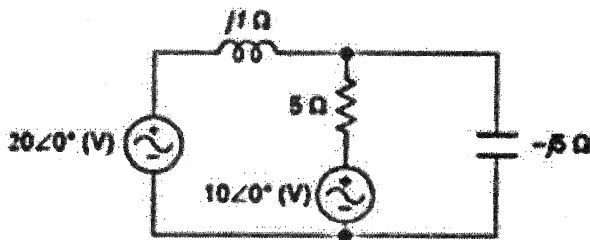

B.TECH. DEGREE EXAMINATION, AUGUST 2021

I B.Tech. I Semester**BASIC ELECTRICAL ENGINEERING**

(CSE, IT and AI & DS)

Time : 3Hrs

Max. Marks : 60

Answer **SIX** Questions, Choosing **ONE** Question from each section
All Questions carry equal marks

* * *

SECTION - I

1. (a) A voltage waveform shown in figure is applied across a 1 F capacitor. Draw the current waveform.

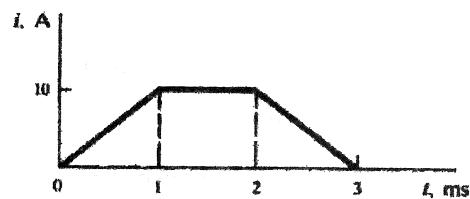

- (b) Find the equivalent resistance between the terminals AB shown in the figure.

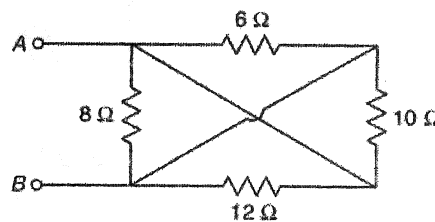

2. (a) Using source transformation, find the voltage V_o shown in the circuit.

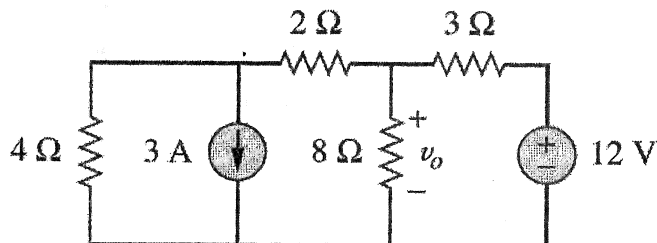

- (b) Find the power delivered by the 50 V source to the circuit shown in the figure.

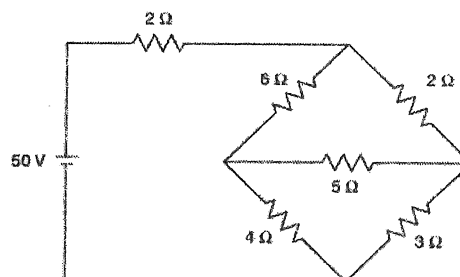

SECTION - II

3. In the circuit shown in figure, write three node equations for nodes A, B, and C, with node D as the reference, and find the node voltages.

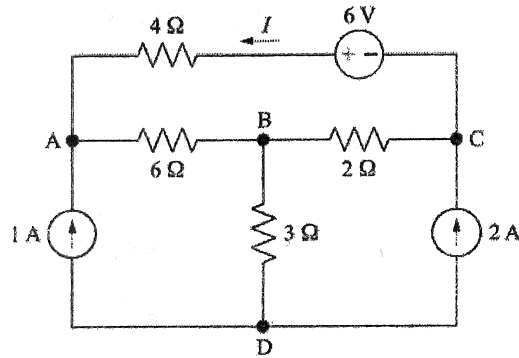

4. (a) State and explain Reciprocity theorem.
 (b) In the circuit shown below, find the voltage across the 20Ω resistor using Superposition theorem.

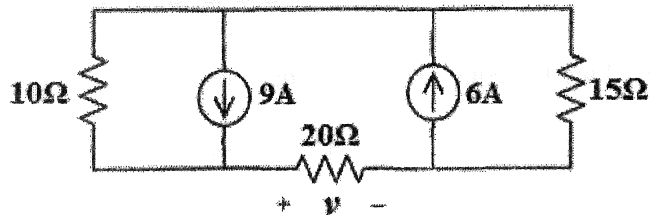

SECTION - III

5. (a) Obtain the RMS value of a sinusoidal voltage of peak V_m and angular frequency ω rad/s.
 (b) A 10Ω resistor is in series with a 80 mH inductor and the combination is connected across a 110 V, 50 Hz source. Obtain the values of
 (i) Total impedance of the circuit,
 (ii) Input current,
 (iii) Voltage across the resistance and inductor.
6. (a) Obtain the Average value of a sinusoidal voltage of peak V_m and angular frequency ω rad/s.
 (b) A voltage $v(t) = 150\sin 10^3 t$ is applied to a series RLC circuit where $R=40\Omega$, $L=0.13$ H and $C=10\mu\text{F}$. Calculate
 (i) Active power supplied by the source,
 (ii) Reactive power supplied by the source and
 (iii) Power factor.

SECTION - IV

7. (a) Mention the various types of losses in a transformer? Suggest the measures to reduce the losses.
- (b) A single-phase, 100-kVA, 2000-V/200-V, 50-Hz transformer has impedance drop of 10 % and resistance drop of 5 %. (a) What is the regulation at full-load 0.8 power factor lagging?
8. (a) Distinguish between step-up and step-down transformers and mention the quantities which remains unchanged during step-up or step-down?
- (b) A 10-kVA, 200-V/400-V, 50-Hz, single-phase transformer gave the following test results :
- OC test (HV winding open): 200 V, 1.3 A, 120 W.
- SC test (LV winding shorted): 22 V, 30 A, 200 W.
- Calculate (a) the magnetizing current, and (b) the equivalent resistance and leakage reactance as referred to the low voltage side.

SECTION - V

9. (a) Explain, how a rotating magnetic field is produced in a three-phase induction motor?
- (b) A three phase 5 hp, 208 V, 60 Hz induction motor runs at 1746 rpm when it delivers rated output power. Determine:
- I. The number of poles,
 - II. The slip at full load,
 - III. The frequency of the rotor current.
10. (a) Describe with a neat diagram, the principle of operation of three-phase induction motor.
- (b) The following are the test results obtained for three phase, 100 hp, 460 V, eight pole star connected squirrel cage induction machine:
- No-load test: 460 V, 60 Hz, 40 A, 4.2 kW
- Blocked rotor test: 100 V, 60 Hz, 140 A, 8 kW
- The average DC resistance between two stator terminals is 0.152 Ohms, determine the parameters of the equivalent circuit.

SECTION - VI

11. (a) Discuss the use of basic PMMC instrument as (a) ammeter, (b) voltmeter.
- (b) Draw the constructional details of PMMC instrument & explain its operation.
12. (a) State the advantages & disadvantages of MI type instruments.
- (b) Draw the constructional details of repulsion type M.I instrument & explain its operation.

B.TECH. DEGREE EXAMINATION, AUGUST 2021

I B.Tech. I Semester**ENGINEERING MATHEMATICS - I****(Common to All Branches)**

Time : 3Hrs

Max. Marks : 60

*Answer SIX Questions, Choosing ONE Question from each section**All Questions carry equal marks*

* * *

SECTION - I

1. (a) Solve $(1 + e^{x/y})dx + (1 - x/y)e^{x/y}dy = 0$

(b) Solve $\frac{dy}{dx} + \frac{y}{x \log x} = \frac{\sin 2x}{\log x}$

2. Solve $\frac{dy}{dx} + x \sin 2y = x^3 \cos^2 y$

SECTION - II

3. (a) Solve $\frac{d^3y}{dx^3} - 6\frac{d^2y}{dx^2} + 11\frac{dy}{dx} - 6y = e^{-2x} + e^{-3x}$

(b) Solve $(D^2 - 4D + 4)y = 8x^2 e^{2x} \sin 2x$

4. Solve $(D^2 + 3D + 2)y = e^{-x} + x^2 + \cos x$

SECTION - III

5. (a) Find the Laplace Transforms of i) $\cos^2 2t$ ii) $\sin t \sin 2t$

(b) Evaluate $L\{e^{-3t}(2 \cos 3t - 3 \sin 4t)\}$

6. (a) Find $L\{t(3 \sin 2t - 2 \cos 2t)\}$

(b) Find the Laplace Transform of $\frac{\cos 2t - \cos 3t}{t}$

SECTION - IV

7. (a) Find the Inverse Laplace Transform of $\frac{s^2 + s - 2}{s(s + 3)(s - 2)}$

(b) Using the Convolution Theorem find $L^{-1}\left\{\frac{s}{(s^2 + a^2)^2}\right\}$

8. Solve $\frac{d^2x}{dt^2} + 3\frac{dx}{dt} + 2x = e^{-t}$, Given that $x(0) = 0$ and $x'(0) = 1$

SECTION - V

9. (a) Find the rank of the following matrix, by reducing into the echelon form

$$\begin{bmatrix} 2 & 1 & 3 & 5 \\ 4 & 2 & 1 & 3 \\ 8 & 4 & 7 & 13 \\ 8 & 4 & -3 & -1 \end{bmatrix}$$

(b) Show that the equations $x + y + z = 6$, $x + 2y + 3z = 14$, $x + 4y + 7z = 30$ are consistent and solve them

10. Find the eigen values and the corresponding eigen vectors of the matrix

$$A = \begin{bmatrix} 8 & -6 & 2 \\ -6 & 7 & -4 \\ 2 & -4 & 3 \end{bmatrix}$$

SECTION - VI

11. (a) Expand $\log(1 + e^x)$ in ascending powers of x

(b) Find the maximum and minimum values of $x^3 + y^3 - 3axy$, $a > 0$

12. Find volume of the largest rectangular parallelepiped that can be inscribed in

ellipsoid $\frac{x^2}{a^2} + \frac{y^2}{b^2} + \frac{z^2}{c^2} = 1$

R-20

Code : 20SH1102

B.TECH. DEGREE EXAMINATION, AUGUST 2021

I B.Tech. I Semester

APPLIED PHYSICS

(Common to EEE, CSE, IT & AIDS)

Time : 3Hrs

Max. Marks : 60

*Answer SIX Questions, Choosing ONE Question from each section
All Questions carry equal marks*

* * *

SECTION - I

1. (a) Demonstrate the formation of Interference fringes in Young's double slit experiment and Interference is the phenomenon of redistribution of light energy – justify your answer.
(b) Distinguish between single slit and double slit diffraction patterns.
2. (a) Analyze how laser light is different from ordinary light.
(b) With the help of suitable diagrams, explain the construction and working of He-Ne laser.

SECTION - II

3. (a) Explain unit cell and lattice parameters of a crystal.
(b) Describe powder method of X-ray diffraction to determine the crystal structure.
4. (a) Write the properties of ultrasonics.
(b) Illustrate one of the method of detecting ultrasonic waves.

SECTION - III

5. (a) Solve Schrodinger's time independent wave equation for a free particle.
(b) For a free particle within a one dimensional potential box, the ground state energy can't be zero. Simplify your answer.
6. (a) Write the significance of Fermi-Dirac distribution function.
(b) Summarize the salient features of Kronig-Penny model of a crystal.

SECTION - IV

7. (a) Explain intrinsic and extrinsic semiconductors with neat diagrams.
(b) Classify drift and diffusion currents in semiconductors and deduce Einstein relation.
8. (a) Discuss direct band gap and indirect band gap semiconductors.
(b) Explain the working of LED and write its advantages in electronic displays.

SECTION - V

9. (a) Discuss the significance of polarizability and dielectric constant of a material and how these two parameters are related with each other.
(b) Mention the applications of dielectrics.
10. (a) Explain the concept of origin of magnetism in materials..
(b) Compare and contrast soft and hard magnetic materials.

SECTION - VI

11. (a) Explain the critical parameters of superconductor.
(b) Outline the concept of DC & AC Josephson effects.
12. (a) With an example, show that surface to volume ratio is very large for nano materials compared to bulk materials.
(b) Categorize and simplify the basic methods for the synthesis of nanomaterials.

B.TECH. DEGREE EXAMINATION, AUGUST 2021**I B.Tech. I Semester****ENGINEERING CHEMISTRY****(Common to CE & ME)**

Time : 3Hrs

Max. Marks : 60

*Answer SIX Questions, Choosing ONE Question from each section**All Questions carry equal marks*

* * *

SECTION – I

1. (a) What is meant by carbonate and non-carbonate hardness of water? What are different units used in expression?
(b) Explain the processes of scale and sludge formation in boilers.
2. (a) What is meant by boiler corrosion? Explain the caustic embrittlement with necessary chemical reactions.
(b) Describe the ion-exchange process for softening of water? What are its advantages and limitations?

SECTION – II

3. (a) What is a fuel cell? How does it differ from the commercial galvanic cells?
(b) Describe the construction, working and applications of lithium ion battery.
4. (a) Explain the Nernst equation for electrode potential.
(b) Define the term 'molecular conductance'. What is the relationship between specific conductance, equivalent conductance and molecular conductance?

SECTION – III

5. (a) Explain the significance of pilling Bedworth rule to explain the corrosion?
(b) Define corrosion of metals and explain the mechanism of electrochemical corrosion?
6. (a) Explain the theory and mechanism of corrosion.
(b) Describe the cathodic protection of corrosion control.

SECTION – IV

7. (a) Explain the differences between thermoplastics and thermosetting plastics?
(b) Explain preparation, properties and uses of nylons.

8. (a) Distinguish between addition and condensation polymerization.
(b) Describe the preparation, properties and uses of Buna N rubber.

SECTION – V

9. (a) Discuss the ultimate analysis of coal with its significance.
(b) Write short notes on producer gas.
10. (a) Explain the proximate analysis of coal to ascertain its quality.
(b) Describe the method of determination of calorific value of solid fuel by bomb calorimeter.

SECTION – VI

11. (a) By writing the various chemical reactions involved, explain the setting and hardening of cement
(b) What is pyrometric cone equivalent? How it is determined for a refractory?
12. (a) Define refractories. What are the characteristics of a good refractory?
(b) Discuss the important functions of lubricants.

R-20

Code : 20SH1104

B.TECH. DEGREE EXAMINATION, AUGUST 2021

I B.Tech. I Semester

APPLIED CHEMISTRY

(Electronics & Communication Engineering)

Time : 3Hrs

Max. Marks : 60

*Answer SIX Questions, Choosing ONE Question from each section
All Questions carry equal marks*

* * *

SECTION - I

1. (a) Explain the significance of Ψ and Ψ^2 .
(b) Write Schrodinger wave equation in Cartesian coordinate and explain the terms.
2. (a) Draw MO energy level diagrams for N_2 and NO and work out the bond orders of these molecules.
(b) What are π -molecular orbitals and explain with respect to butadiene and benzene

SECTION - II

3. (a) What is the role of doping on band structures? Explain.
(b) Explain the band theory of solids.
4. (a) Explain the pattern of d orbitals splitting in a square planar crystal field?
(b) Give the properties and future applications of nanomaterials such as fullerenes and graphene.

SECTION - III

5. (a) Explain the basic principle, construction and working of a galvanic cell with a neat diagram.
(b) Describe the construction and working of lead-acid battery with reactions.
6. (a) Write a brief notes about (i) primary cells (ii) secondary cells.
(b) Derive Nernst equation for the calculation of cell emf.

SECTION - IV

7. (a) Write a short notes on (i) Dry corrosion (2) Galvanic corrosion
(b) Discuss in detail about electroplating and electroless plating metallic coatings.

8. (a) State and explain pilling-Beidworth rule. Discuss the role of nature of oxide formed in oxidation corrosion.
(b) Explain sacrificial anodic protection method of controlling corrosion.

SECTION - V

9. (a) Write short notes (i) Copolymerization (ii) Differences of Thermoplast and Thermoset.
(b) Distinguish between Addition and condensation polymerizations.
10. (a) Explain the preparation, properties and uses of Phenol-formaldehyde and Polyvinyl chloride.
(b) How are the following produced? (i) Buna-S (ii) Thiokols. Mention their properties and uses.

SECTION - VI

11. (a) What is meant by refining of crude oil? Discuss the procedure involved in refining of crude petroleum oil.
(b) Explain the preparation, properties and uses of producer gas and water gas.
12. (a) Describe about construction and working principle of bomb calorimeter for the estimation of calorific value of solid fuel.
(b) Write short notes on (i) Characteristics of a good fuel (ii) relative merits and demerits of solid, liquid and gaseous fuels.

B.TECH. DEGREE EXAMINATION, AUGUST 2021

I B.Tech. I Semester**COMMUNICATIVE ENGLISH**

(Common to All Branches)

Time : 3Hrs

Max. Marks : 60

*Answer SIX Questions, Choosing ONE Question from each section
All Questions carry equal marks*

* * *

SECTION - I

1. (a) Do you agree with William Hazlitt's belief that in being school will teach his son about how to get along with other and prepare him for life? Explain with examples from On the conduct of life and your own experience.
- (b) Name the part of speech of each underlined word in the following sentences.
 - i. I will watch while you sleep.
 - ii. Do you like dogs?
 - iii. Has your father ever been to America?
 - iv. My brother helped an old lady.
 - v. Meghana likes gardening.
2. (a) Write a paragraph on "Need for a skill-based curriculum".
- (b) Rewrite the following in right order.
 - i) Gulmarg / with / very / tourists / popular / is
 - ii) high / blood / many / pressure / be / there / can / causes / of
 - iii) the idea/to me/watching/I was/with/came/when/its wings/the bird/taking off
 - iv) to stay/language/appears/English/for long/it/has come/with us
 - v) darkness/the inside/due to/the van/I/of/couldn't see

SECTION - II

3. How does Tennyson draw parallelism between the journey of the brook and the life of man? Explain in detail.
4. (a) Fill in the blanks with suitable articles.
 - i. You are ___ unreliable person.
 - ii. ___ European and ___ Indian visited my office this morning.
 - iii. ___ boiling water is converted into steam.
 - iv. How blue ___ sky looks!
- (b) Fill in the blanks with suitable prepositions.
The robbers were caught _____ the police _____ forty-eight hours _____ the robbery. They were fighting _____ themselves _____ the loot when the police surrounded their hideout

SECTION – III

5. (a) What kind of a person is Prince Dimitri? Analyze and comment on his character.
(b) Discuss the significance of the title 'The Death Trap'?
6. (a) You are one of the student coordinators for the conduct of Farewell Day at your college. Draft a speech to be delivered before senior students
(b) Fill in the blanks with right answer following the rules of Subject - Verb Agreement.
1. A theory of physics _____ (ascertain/ascertains) that a body in motion stays in motion.
 2. Peter ____ (does not / do not) like vegetables.
 3. Each ____ (get/gets) a certificate for participating.
 4. The couch and chair _____ (look/looks) really nice in here.
 5. There ____ (is/are) seven clean plates in the dining room.

SECTION – IV

7. What is the role Mohammad Yunus played in eradicating poverty and empowering women in Bangladesh. Explain in detail.
8. (a) Write the following as directed.
1. She is cleverer than her brother. (Change into positive degree)
 2. Taj Mahal is one of the most beautiful monuments. (Change into comparative degree)
 3. Delhi is the more polluted than any other city in India (Change into Superlative degree)
 4. Write antonyms to the following words.
i) BRAVE ii) EXTERIOR
- (b) Fill in the blanks with right quantifier given in the brackets.
- i. In my opinion, ____ (all/enough) meat, red or white, is bad for you.
 - ii. Can we have two _____ (more/enough) cakes please?
 - iii. _____ (little/small) knowledge a bad thing.
 - iv. There is not ____ (no/any) milk left.
 - v. Raju has _____ (more/enough) courage to accept his mistakes.

SECTION – V

9. (a) The author says political language is designed to twist meaning. Do you agree with this statement? Substantiate your answer with examples.
(b) What do you think the author means by "What is above all needed is to let the meaning choose the word"?
10. (a) Write a letter to the Sales Distributor, Samsung Electronics, Hyderabad, complaining about the washing machine that is not functioning properly.
(b) Rewrite the following as directed.
1. My uncle gave me a present. (Begin with 'I')
 2. My father went to the market, _____? . (Add question tag)
 3. My teacher asked me, "Why did you not submit assignment?"
(Change into Indirect speech)
 4. Write the meanings of the following one- word substitutes.
i) Aviation ii) Chronology

R-20

Code : 20CS1101

B.TECH. DEGREE EXAMINATION, AUGUST 2021

I B.Tech. I Semester

PROGRAMMING FOR PROBLEM SOLVING

(Common to All Branches)

Time : 3Hrs

Max. Marks : 60

*Answer SIX Questions, Choosing ONE Question from each section
All Questions carry equal marks*

* * *

SECTION - I

1. (a) What is flow chart? Explain different symbols used to design a flow chart.
(b) Draw a flow chart to find positive difference of two numbers.
2. (a) Explain structure of C program.
(b) What is constant? Explain different types constants used in C.

SECTION - II

3. (a) Explain use of relational and logical operator with example program.
(b) Develop a C program to convert Celsius to Fahrenheit. Formula $C = (F - 32) * 5/9$.
4. (a) What are the unformatted input and functions in C? Explain with examples.
(b) Explain any four commonly used C library functions with examples.

SECTION - III

5. (a) What is the use of switch statement? Explain with example program.
(b) Explain goto statement with example program.
6. (a) Compare while loop and do-while loop.
(b) Develop a C code to find given number is palindrome or not.

SECTION - IV

7. (a) Explain declaration and initialization two dimensional arrays.
(b) Develop a C program to find transpose of matrix.
8. (a) What is string? Explain declaration and initialization of strings.
(b) Explain the use of extern storage class with example program.

SECTION - V

9. (a) Explain how to access array elements by using pointers with example program.
(b) How to access strings by using pointers?
10. (a) What is function prototype? Compare formal arguments and actual arguments.
(b) Explain how to return multiple values by functions.

SECTION - VI

11. (a) How to create user defined data types? Explain with example.
(b) Discuss about declaration and initialization of structures.
12. What are the different modes available to open a file? Explain with examples.